

ZEMPER

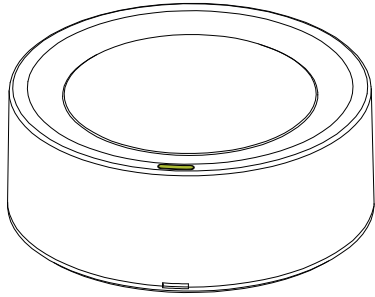

SPAZIO LUZ

LSC / IP-42 IK-04

1 Présentation

Conforme a EN 60598-2-22

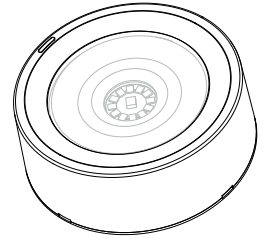

Le luminaire est composé d'une patte de fixation, d'un boîtier électronique ainsi que d'un diffuseur.

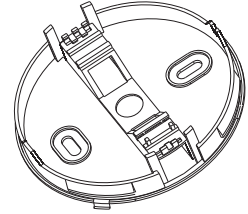

2 Installation

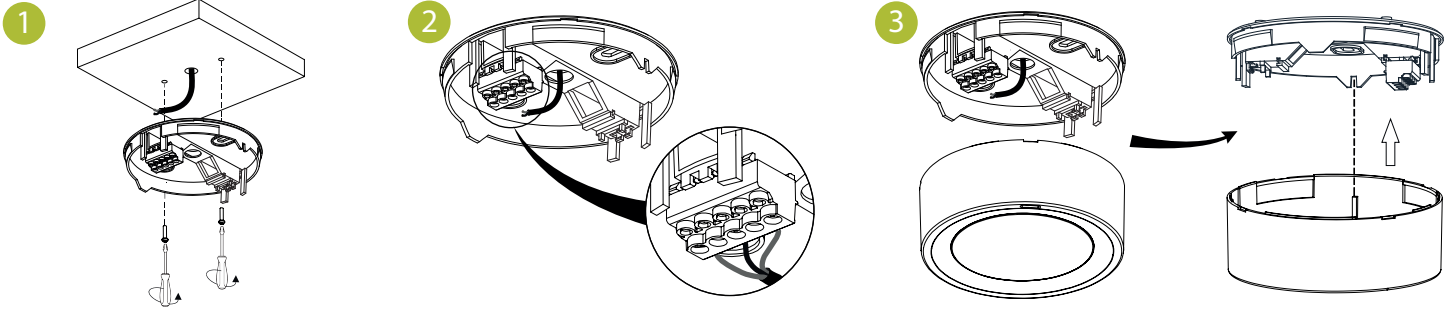

3 Raccordement et test

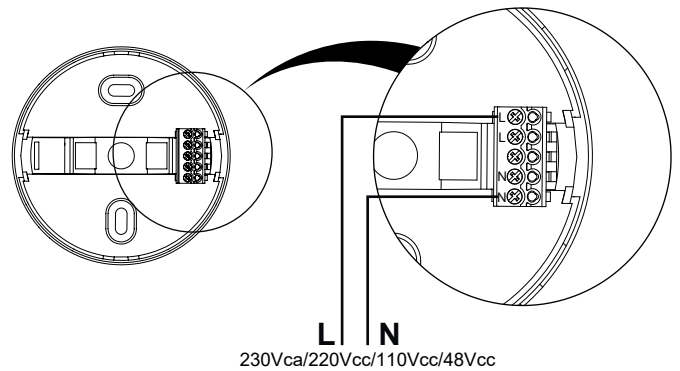
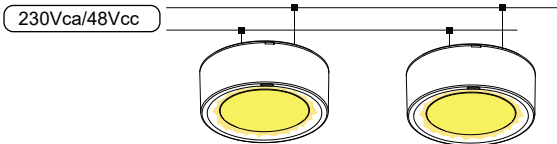

Marquage du luminaire

Z: LSC
0: Non permanent
1: Permanent



Courbes sur demande

Pieces detachees

	Permanent	Non permanent	W			N° HOMOL.
LSC LUZ-0448/23	45 lm	45 lm	< 2.3 VA ca/0.65W cc	4x LED 0.5W	230Vca/48Vcc	19072/741530
LSC LUZ-4048/23	340 lm	340 lm	< 7.5 VA ca/3.5W cc	12x LED 0.5W	220Vcc/110Vcc	19073/741532

ATTENTION: Afin de pouvoir réaliser un entretien correct, conserver ce mode d'emploi.

POUR TOUS RESEIGNEMENTS TECHNIQUES

APPELEZ AU +333.85.34.66.20